

Series 11 Miniature Pneumatic Solenoid Valve

15 mm Solenoid Valve



The Series 11 miniature pneumatic solenoid valve is a robust and proven product with a reputation for reliable and consistent performance. The Series 11 miniature solenoid valve is the preferred choice of major OEM's in the medical and analytical market. With valve bodies made from brass or stainless steel, the Series 11 miniature solenoid valve is an ideal solution for general purpose applications and those applications requiring low out-gassing and a bubble-tight seal.

Applications

- Oxygen Conservers
- Oxygen Concentrators
- Compression Therapy
- Gas Chromatography
- Insufflators
- Medical & Analytical Gas Control

Features

- Proven performance tested to 260 million life cycles
- Wide range of available electrical connections to simplify valve integration and control
- Manifold mount or barbed tube pneumatic configurations available for added system design flexibility
- Available Analytical and Oxygen Service Clean to minimize contamination
- RoHS compliant 

Product Specifications

Mechanical

Valve Type:

Solenoid-actuated poppet style
 - 2/3 Port, Normally Closed (NC)
 - 2/3 Port, Normally Open (NO)
 - 3 Port, Distributor
 - 2 Port, Normally Closed (NC) - Universal

Media:

Air, argon, helium, hydrogen, methane, nitrogen, oxygen, & other non-reacting gasses

Operating Environment:

32 to 158°F (0 to 70°C)

Storage Temperature:

-40 to 158°F (-40 to 70°C)

Dimensions:

- Length: 1.73 in (43.9 mm)
 - Width: 0.63 in (15.8 mm)
 - Height: 0.67 in (17.0 mm)

Weight:

2.1 oz (60 g)

Internal Volume:

0.026 in³ (0.426 cm³)

Filtration:

40 micron (recommended)

Oxygen Clean:

Call For Details

Electrical

Power Options:

0.5, 1.0, or 2.0 Watts

Voltage Options:

5, 12 or 24 VDC
 Further power reduction may be achieved through the use of spike and hold or PWM electrical control.

Electrical Connections:

Wire Leads, PC Pins, Solder Tabs, Quick Disconnect Spade

Wetted Materials

Body:

36000 HO2 Brass;
 303 Series Stainless Steel

Stem Base:

36000 HO2 Brass;
 303 Series Stainless Steel

Poppet Options:

FKM

All Others:

430 FR Series Stainless Steel
 302 Series Stainless Steel

Performance Characteristics

Leak Rate:

<0.016 sccm of air
 1.0 sccm of air (Model 20 only)

Response:

<30 ms cycling

Pressure:

0 to 100 psig (6.9 bar)

Vacuum:

0-27 in Hg (686 mm Hg)

Orifice Sizes:

0.030" (0.76 mm)
 0.050" (1.27 mm)
 0.102" (2.59 mm)

Series 11 Miniature Pneumatic Solenoid Valve Typical Flow Curve

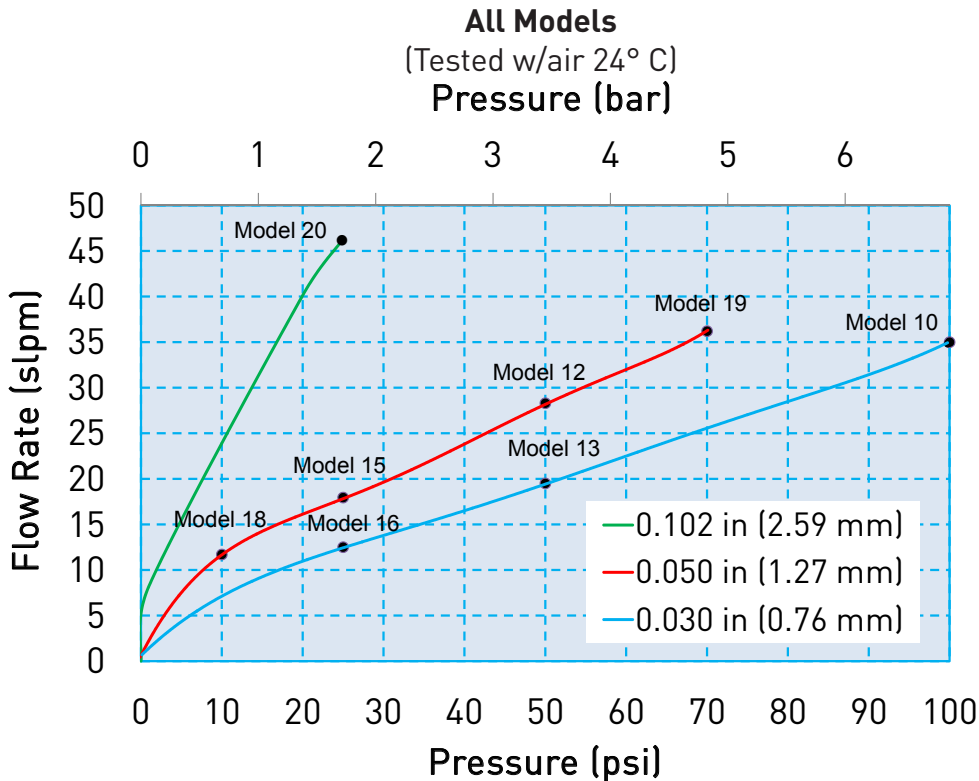

All models reflect typical flow output capability based on rated pressure

Pressure and Flow Capabilities/Life Requirements

Model No.	Orifice Size	Nominal Cv	Maximum Supply Pressure	Leak Rate (Air)	Power Consumption	Elastomer	Life Requirements (millions of cycles)*
10	0.030 in (0.76 mm)	0.017	100 psi (6.89 bar)	<0.016 sccm	2 Watts	FKM	100
12	0.050 in (1.27 mm)	0.031	50 psi (3.45 bar)	<0.016 sccm	2 Watts	FKM	100
13	0.030 in (0.76 mm)	0.017	50 psi (3.45 bar)	<0.016 sccm	1 Watt	FKM	200
15	0.050 in (1.27 mm)	0.025	25 psi (1.72 bar)	<0.016 sccm	1 Watt	FKM	200
16	0.030 in (0.76 mm)	0.017	25 psi (1.72 bar)	<0.016 sccm	0.5 Watt	FKM	260
18	0.050 in (1.27 mm)	0.021	10 psi (0.69 bar)	<0.016 sccm	0.5 Watt	FKM	260
19	0.050 in (1.27 mm)	0.025	70 psi (4.83 bar)	<0.016 sccm	2 Watts	FKM	20
20	0.102 in (2.59 mm)	0.069	25 psi (1.72 bar)	1.0 sccm	1 Watt	FKM	25

*Life is dependent upon elastomeric material, duty cycle and pressures

For custom requirements please contact Applications Engineering at 603-595-1500 or ppfinfo@parker.com



Series 11 Miniature Pneumatic Solenoid Valve Pneumatic Interface

Manifold Mount



Mechanical Integration Dimensions

Basic Dimensions, 2-Way Valve Configuration

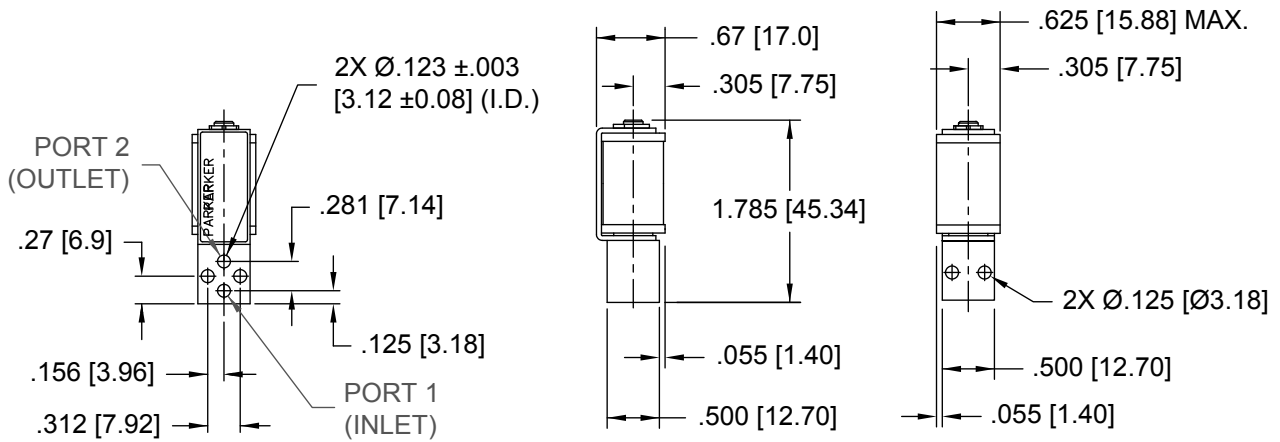

UNITS
IN. [mm.]

Basic Dimensions, 3-Way Valve Configuration

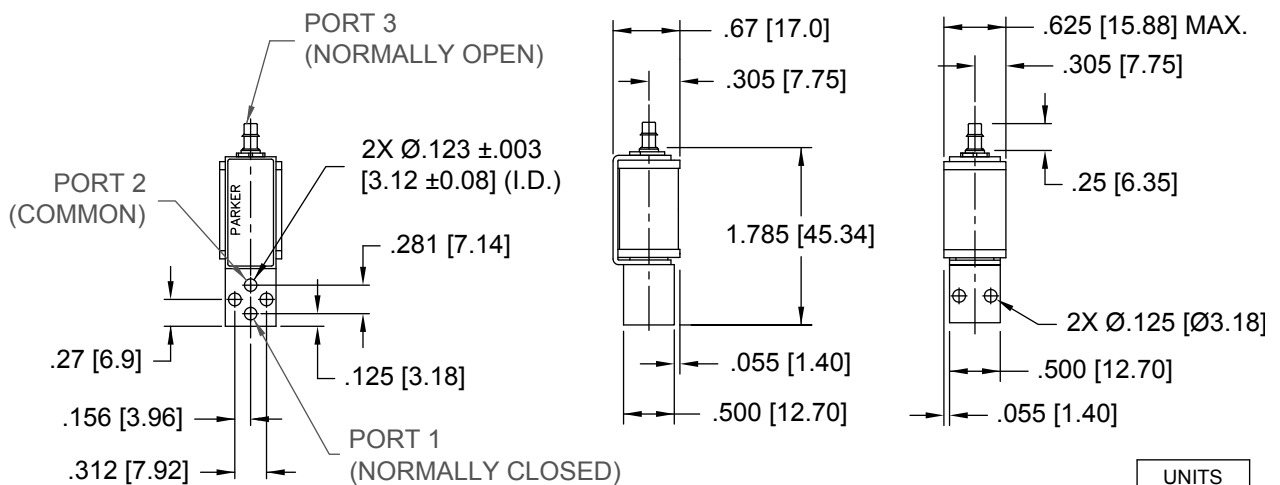

UNITS
IN. [mm.]



Series 11 Miniature Pneumatic Solenoid Valve Pneumatic Interface

Barbed



Barb Options

1/16" (1.5 mm) Barbs

(For 1/16" (1.5 mm) I.D. Tubing)

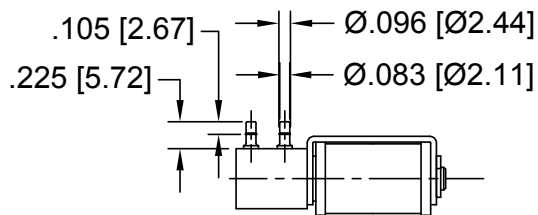

5/64" (2 mm) Barbs

(For 5/64" (2 mm) I.D. Tubing)

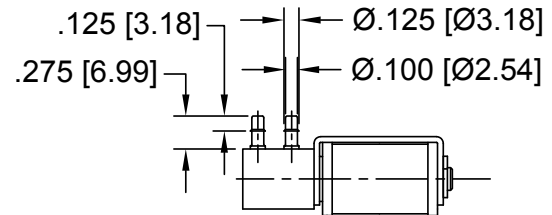

1/8" (3 mm) Barbs

(For 1/8" (3 mm) I.D. Tubing)

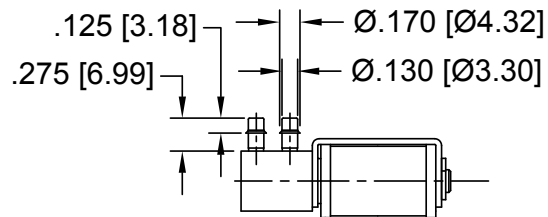

Series 11 Miniature Pneumatic Solenoid Valve Electrical Interface

Coil Type: Wire Leads (See Order Info "F")

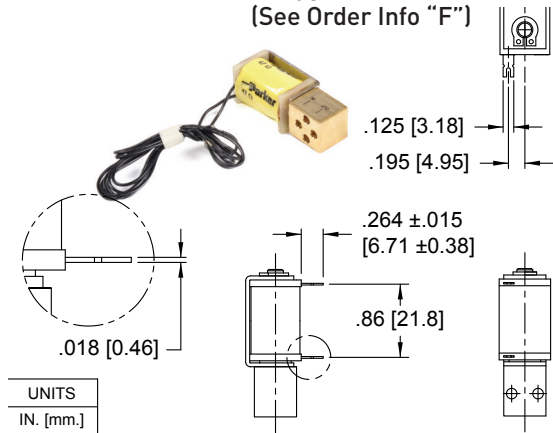

Coil Type: Quick Connect Spade (See Order Info "Q")

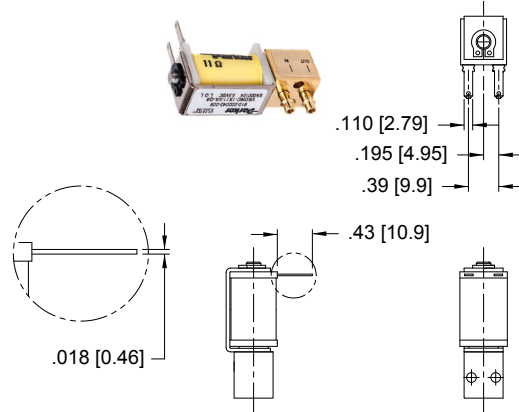

Coil Type: Solder Tab (See Order Info "S")

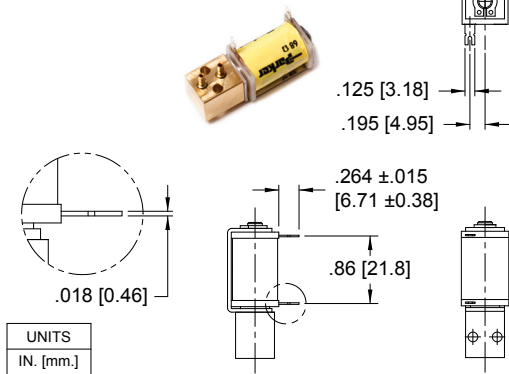

Coil Type: 4 PC Pins* (See Order Info "P")

*See Isometric Drawing below

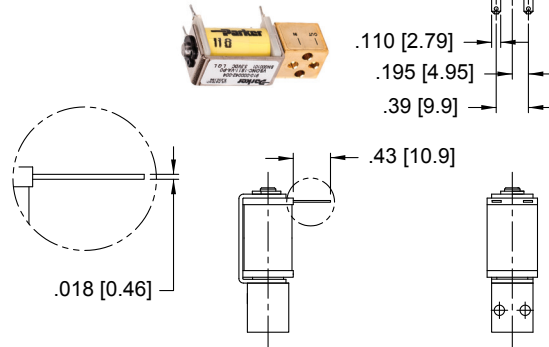

*4 PC PIN PCB Interface

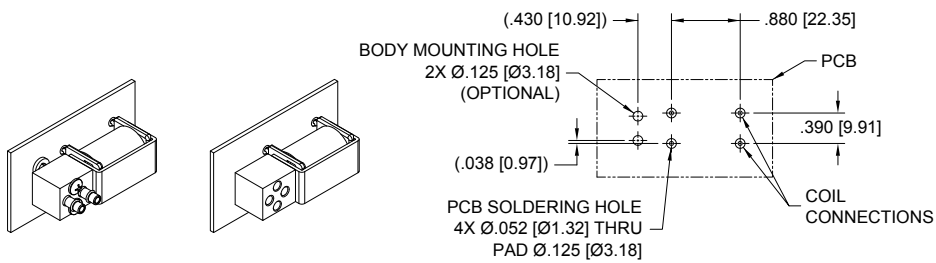

Series 11 Miniature Pneumatic Solenoid Valve ANSI Symbols

LEGEND:	
SUPPLY:	Pneumatic Source or Supply Pressure
EXHAUST:	Exhaust to Atmospheric Pressure
REQMT:	Customer Requirement or Application
ATM:	Atmospheric Pressure

Pneumatic Schematics by Valve Types

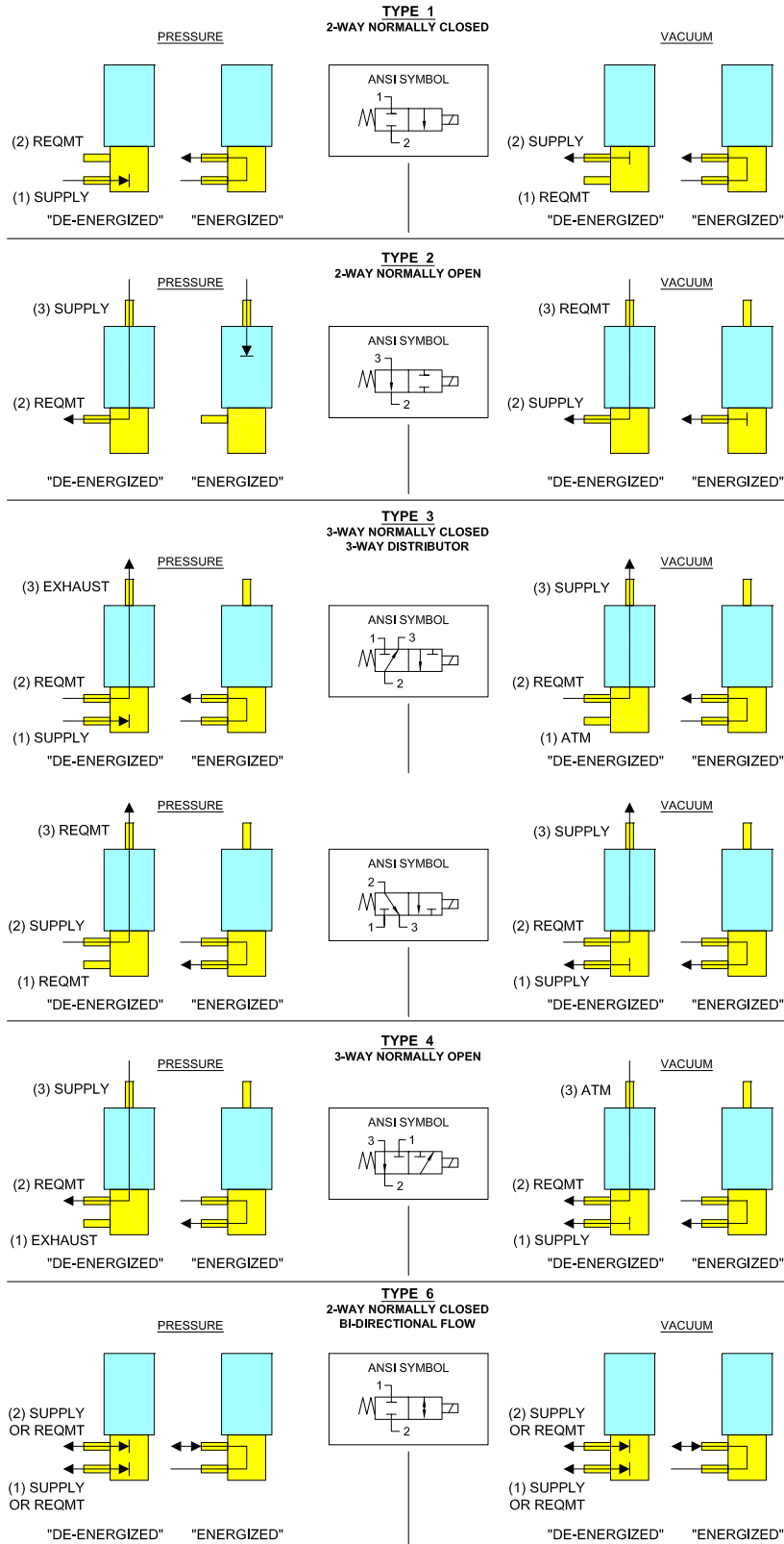

Series 11 Miniature Pneumatic Solenoid Valve Installation and Use

Manifold & O-Ring Dimensions & Design

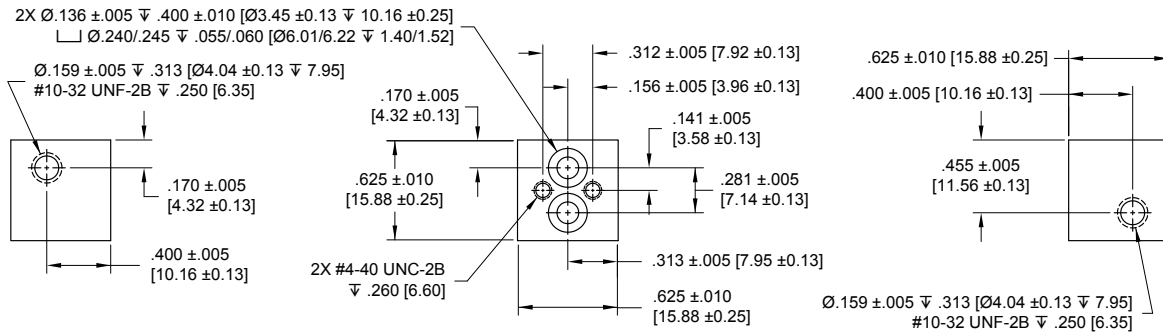

Accessories

O-Ring (Manifold Seal) Dimensions

(see Accessories table below for part numbers)

I.D. = $\varnothing .114 \pm .005$ [$\varnothing 2.90 \pm 0.13$]
 W = $.070 \pm .003$ [1.78 ± 0.08]
 O.D. = $\varnothing .254$ [$\varnothing 6.45$] REFERENCE

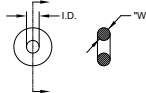

Body Standoff

890-000027-001

(2 required for each valve)

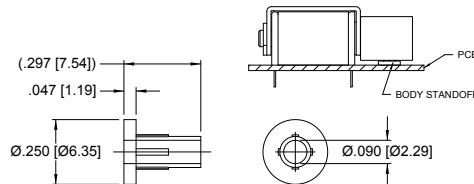

Screw 4-40 x 1/2" Pan Head

191-000100-208

(2 required for each valve)



Series 11 Miniature Pneumatic Solenoid Valve

Ordering Information

Sample Part ID	11	10	3	BV	12	P	7	7
Description	Series	Model Number Pressure / Orifice / Power	Type	Material XX: Body / Poppet & Seal	Voltage	Electrical Coil Connection	Pneumatic Connection Body	Pneumatic Connection Stem
Options	11	10: 0-100 psi / 0.030" / 2 Watts 12: 0-50 psi / 0.050" / 2 Watts 13: 0-50 psi / 0.030" / 1 Watt 15: 0-25 psi / 0.050" / 1 Watt 16: 0-25 psi / 0.030" / 0.5 Watt 18: 0-10 psi / 0.050" / 0.5 Watt 19: 0-70 psi / 0.050" / 2 Watts 20: 0-25 psi / 0.102" / 1 Watt	1: 2-Way NC 2: 2-Way NO 3: 3-Way NC or Distributor 4: 3-Way NO 6: 2-Way NC Universal ⁽¹⁾	BV: Brass / FKM ⁽²⁾ SV: Stainless Steel / FKM	5: 5 VDC 12: 12 VDC 24: 24 VDC	F: Wire Leads, 18", No Termination P: PC Mount, 4 PC Pins S: PC Mount, 2 Solder Tabs Q: Quick Connect Spade	0: Manifold Mount ⁽³⁾ 6: 1/16" (1.5 mm) Barbs 7: 5/64" (2 mm) Barbs 8: 1/8" (3 mm) Barbs	0: Manifold Mount ⁽⁴⁾ 6: 1/16" (1.5 mm) Barbs ⁽⁵⁾ 7: 5/64" (2 mm) Barbs 8: 1/8" (3 mm) Barbs
			⁽¹⁾ Model 20 (0.102" orifice) only available in 2-Way NC Universal configuration	⁽²⁾ Model 20 (0.102" orifice) only available in Brass/FKM configuration			⁽³⁾ Model 20 (0.102" orifice) only available in manifold mount body	⁽⁴⁾ Type 1 and 6 configurations only ⁽⁵⁾ Not available on Models 12, 15, 18 and 19 (0.050" orifice)

Accessories	
190-007024-001: O-ring, Buna-N*	* Used as a seal between the manifold and valve body
190-007024-002: O-ring, FKM *	** Used to create a flush mount between the coil and valve body
890-000027-001: Body Standoff **	
191-000115-010: Screw, 4-40 x 5/8" Pan Head, Phillips	



NOTE: In order to provide the best possible solution for your application, please provide the following requirements when contacting Applications Engineering:

- Media, Inlet & Outlet Pressures
- Minimum Required Flow Rate
- System Supply Voltage
- Media
- Ambient Temperature Range

Please click on the Order On-line button (or go to www.parker.com/precisionfluidics/s11) to configure your Series 11 Miniature Pneumatic Solenoid Valve. For more detailed information, visit us on the Web, or call and refer to Performance Spec. #790-002075-001 and #790-002407-001 (Model 20 only) and Drawing #890-003016-001.

For more information call +1 603 595 1500 or email ppfinfo@parker.com
Visit www.parker.com/precisionfluidics

