



# Jauch Battery Solutions

- Reliable energy for your application
- Standard cells and customized packs
- ESD protection
- Battery Certification Experts



RoHS compliant



Pb free



REACH compliant



Conflict mineral free

## Technical Data Sheet · ER2450J-T

### SPECIFICATIONS

Chemistry	Li-SoCl <sub>2</sub>
UI 1642	MH62838
Nominal Voltage	3.6V
Jauch No.	247840
Nominal Capacity	0.50 Ah
Max. Continuous Current	5 mA
Max. Pulse Current	15 mA
Operating Temperature	-55°C to +85°C*
Storage	30°C max
Weight	Approx. 9 gr.

\* In applications where the battery is exposed to temperatures >85°C, please contact Jauch.

### DIMENSIONS

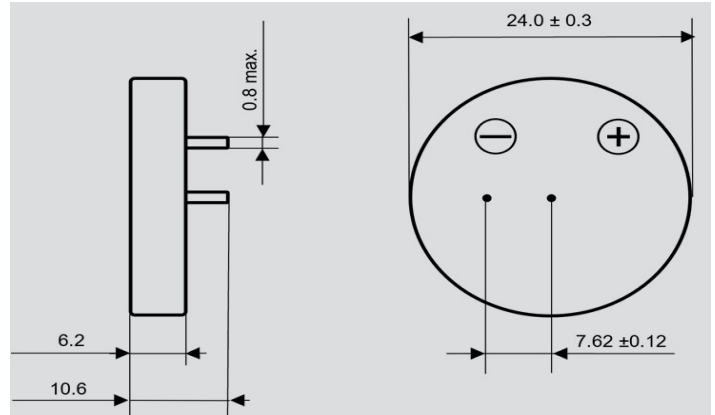

Available Terminals and Wire Connectors: please contact Jauch for diagram of batteries with terminals ([batterytechnology@jauch.com](mailto:batterytechnology@jauch.com)).

### DISCHARGE CHARACTERISTICS

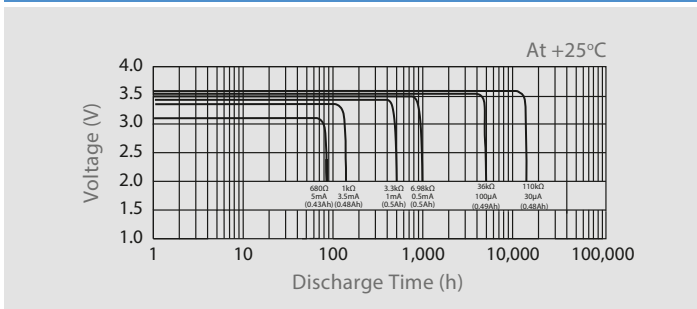

### VOLTAGE VS. TEMPERATURE

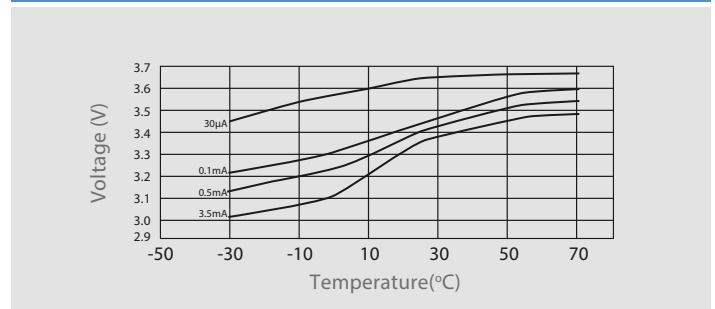

### CAPACITY VS. CURRENT

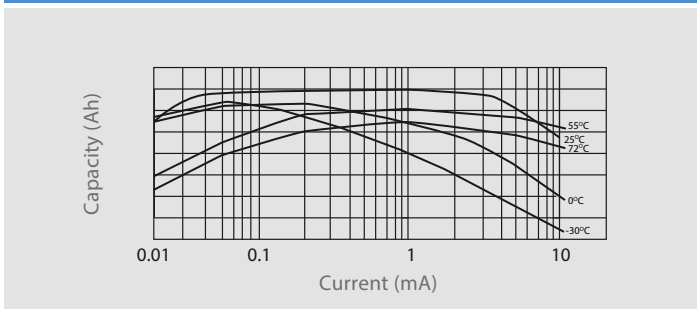

### STORAGE CHARACTERISTICS

