

Technical Data Sheet

SONOFLOW CO.55 V3.0

with display and stainless steel housing

Ultrasonic Flow Sensor for Non-Invasive Flow Measurement



Clamp-on flow meters of the SONOFLOW CO.55 V3.0 series measure the flow rate of liquids in flexible tubes of different diameters. With high accuracy, reproducibility and repeatability – even at the lowest flow rates – they are suitable for a variety of applications. Various accessories allow for easy integration into a range of different process environments. The integrated touch display supports the configuration of some sensor parameters and provides status information. The measured value output can be adapted to individual requirements. In the version with stainless steel housing, the sensor type is specially designed for use in areas with strict hygiene requirements.

Accuracy

SONOFLOW CO.55 type	Accuracy (of reading) on specified tubing ¹		Typical flow range ²
	Low flow range	High flow range	
*/0250SD V3.0	0 ... 150 ml/min: ± 1.5 ml/min	> 150 ml/min: ± 1 %	0 ... 1 000 ml/min
*/0375SD V3.0	0 ... 300 ml/min: ± 3 ml/min	> 300 ml/min: ± 1 %	0 ... 4 000 ml/min
*/0500SD V3.0	0 ... 500 ml/min: ± 5 ml/min	> 500 ml/min: ± 1 %	0 ... 5 000 ml/min
*/0625SD V3.0	0 ... 700 ml/min: ± 7 ml/min	> 700 ml/min: ± 1 %	0 ... 10 000 ml/min
*/0750SD V3.0	0 ... 1 000 ml/min: ± 10 ml/min	> 1 000 ml/min: ± 1 %	0 ... 15 000 ml/min
*/1375SDH V3.0	0 ... 6 000 ml/min: ± 60 ml/min	> 6 000 ml/min: ± 1 %	0 ... 80 000 ml/min

1) Accuracy based on standard calibration conditions as listed. Accuracy depends on tubing, tubing variations, temperature, fluid properties, clamping and other conditions (design of inlet and outlet section).

2) Maximum flow: limited by tubing and pump capacity only.

Calibration conditions

Sensors are factory calibrated under the following standard conditions:

- Tubing as listed in table 'Tubing properties', not sterilized
- Water at 23 °C ± 2 K
- Warm up: at least 30 min
- Zero calibration after clamp-on
- Open tubing outlet (pressure close to zero)

Besides recalibrations of our flow sensors we offer safety inspections and repair service for all our products. Contact us!

Tubing properties

Typical types of tubes are listed below. The sensors are also suitable for comparable flexible tubes (different tube manufacturers, diameters, materials such as PVC, TPE, etc.). If possible, provide a tubing sample (minimum length 75 cm) along with your order.

Sensor variant with cover clasp

Tube type: Masterflex® precision pump tubing, platinum-cured silicone, not sterilized*

SONOFLOW CO.55 type	Inner tube Ø	Outer tube Ø	Tubing details from the manufacturer	
*/0250SD V3.0	1/8" [0.125"]	1/4" [0.250"]	L/S® 16	Item No. 96410-16
*/0375SD V3.0	1/4" [0.250"]	3/8" [0.375"]	L/S® 17	Item No. 96410-17
*/0500SD V3.0	5/16" [0.313"]	1/2" [0.5"]	L/S® 35	Item No. 96410-35
*/0625SD V3.0	3/8" [0.375"]	5/8" [0.625"]	I/P® 73	Item No. 96410-73
*/0750SD V3.0	1/2" [0.5"]	3/4" [0.75"]	I/P® 82	Item No. 96410-82

Sensor variant with handle (H)

Tube type: Saint-Gobain® C-Flex® tubing, thermoplastic elastomer (TPE), not sterilized*

SONOFLOW CO.55 type	Inner tube Ø	Outer tube Ø	Tubing details from the manufacturer	
*/1375SDH V3.0	1"	1 3/8" [1.375"]	374	Item No. 374-1000-6

* Gamma sterilization, x-ray sterilization, or autoclaving of the tubing may impact its material properties, potentially affecting sensor readings. Recalibration may be required after tubing sterilization.

Sensor interfaces

Interface	Specifications
Current output	0 (4) ... 20 mA Resolution: < 1 μ A Update rate: up to 1 kHz Configurable for flow range Load to GND. The max. load depends on the operating voltage: 12 V \rightarrow 250 Ω 15 V \rightarrow 500 Ω 24 V \rightarrow 1 k Ω 30 V \rightarrow 1.2 k Ω
RS-485 interface	RS-485 bus operation: max. 12 subscribers Default address: #01 Available protocols: <ul style="list-style-type: none">• SONOTEC protocol: Half-duplex operation 115 200 baud No parity 1 stop bit no handshaking• Modbus[®] protocol: configurable settings via software
Switching output	Switching characteristics: PNP / NPN / Push-pull 0 ... 30 V max. 100 mA PWM output period: 0.1 ms ... 1 000 ms Output range 0 ... 100 % or 5 ... 95 % Smallest pulse length: 5 μ s Configurable as: <ul style="list-style-type: none">• Volume switch (adapting batch process / dosing)• Threshold switch of flow• Pulses of volume (flexible pulse length, max. 20 kHz)• Flow rate (via frequency or duty cycle)• Status information via switch
Digital input	Internal pull-up to operating voltage (100 k Ω) Voltage resistant up to 30 V Configurable for: <ul style="list-style-type: none">• Zero point calibration of flow• Start dosing processes (reset volume) (Either separate or simultaneous execution possible)

Display

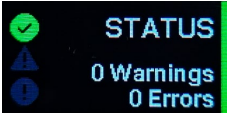
General data	
Display type	TFT-LCD 0.96"(approx. 24 mm) Resolution: 80 × 160 262K Colors
Additional features	Touch operation 3 screen sections
Display (configurable)	<ul style="list-style-type: none">• Measurement values (flow direction, real-time flow data)• Status information 
Status information	<p>Colored bar on the display edge:</p> <ul style="list-style-type: none">• Blue: Sensor error (highest priority)• Red: Measurement error (medium priority)• Yellow: Warning (lowest priority)• Green: Sensor is ready <p>Display of details (if configured)</p> 
Options	Touch operation: Display lock: On / Off Input of values (e.g. PIN) Navigating between display pages Reset off 'Flow' or 'Volume' Adaption of 'Flow factor' (Correction e.g. after tube replacement)
Settings	Parameter adaption (via software, optional accessory): Display: On / Off Touch operation: On / Off Orientation: 0° / 180° Measurement value output: 5 display pages Decimal places: 0 ... 3 Units for 'Flow' and 'Volume'

Electrical specifications and connections

Parameter	Specifications
Operating voltage	12 ... 30 VDC Maximum ripple: 10 % Protection against reverse-polarity (external fuse, if required: min. 200 mA)
Current consumption	Maximum 60 mA (with open current, frequency and switching output, depending on supply voltage) Inrush current (during start-up < 10 ms): < 350 mA at 12 V, < 150 mA at 24 V
Electrical connection	8-pin M12 connector DIN EN 61076-2-101:2012

8 pin connector to 8 pole cable

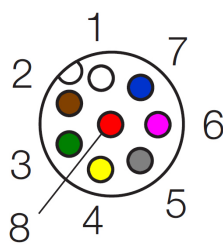
Connection	Pin	Assignment	Color
 <p>Male connector (at the sensor)</p>	1	Ground	White
	2	Operating voltage	Brown
	3	Current output	Green
	4	RS-485 B	Yellow
	5	RS-485 A	Grey
	6	(not assigned)	Pink
	7	Switching output / frequency output	Blue
	8	Digital input	Red
Shielding	Cable shield must be connected to housing		

General data

Parameter	Specifications
Measuring method	Ultrasonic time of flight measurement
Sensor materials	Measuring channel: ABS Housing: Stainless steel 1.4404 Display protection: Glass Connector: Stainless steel
Mounting	4 threaded mounting holes (see 'Technical drawings')
Maintenance	Maintenance-free
Directives and standards	<ul style="list-style-type: none">• EMC Directive 2014/30/EU• RoHS Directive 2011/65/EU, exception: III 7cl/ IV 15; RoHS 2015/863• Acoustic emission: IEC 61157:2007 + A1:2013

Conditions of use

Parameter	Specifications
Customized calibration	Standard calibration according to factory specification. Calibration to deviating, flexible customer tubing, fluid, flow range, temperature, etc. on request.
Operating conditions	Adaptation to different tubes or operating conditions by parameter settings (with the help of optionally available software).
Media	Water or similar liquids
Ambient- / Media temperature	0 ... 60 °C (other temperatures available on request)
Storage temperature	-20 ... +70 °C
Degree of protection	IP65

Scope of supply and accessories

Parameter	Specifications
Scope of supply	<ul style="list-style-type: none">• Sensor SONOFLOW CO.55 V3.0 with display and stainless steel housing according to specification• User documentation• Calibration report
Optional accessories	<p>Sensor cable Length: 2 m 8-pole M12 connector</p> <hr/> <p>SONOFLOW Monitor software for setting parameters, recording measurements and updating sensor software, consisting of</p> <ul style="list-style-type: none">• USB Data Converter Type 013 for the connection to a computer• USB cable, type A-B, length 2 m• Cable 2 m, 8-pole M12 connector• Switching power supply 12 V• Flow Monitor Software Package• User documentation <hr/> <p>SONOFLOW RD.10 Remote Display including connecting cable for</p> <ul style="list-style-type: none">• Monitoring sensor performance (display e.g. current flow rate, volume or measuring state)• Zero calibration• Manual volume reset <hr/> <p>EtherNet/IP Gateway programmed for SONOTEC</p> <ul style="list-style-type: none">• Serial communication with an EtherNet/IP-based system (e.g. PLC)• Support of up to 12 sensors• Pre-configured parameters and commands (library with Modbus registers for time-saving installation) <hr/> <p>Portable USB Data Converter Type 023 for</p> <ul style="list-style-type: none">• Mobile operation of sensors via a standard USB power socket or power bank• Triggering of functions stored for the digital sensor input ('push button switch')

Sensor dimensions and technical drawings

Design data (STEP files) for integration will be provided upon request. Please feel free to contact us.

Sensor variant with cover clasp: small design

SONOFLOW CO.55 type	Product No	Dimensions (L × W × H)	w (W without display)
*/0250 V3.0	200 08 0136	44 × 64.5 × 34 mm	50 mm
*/0375 V3.0	200 08 0137	44 × 64.5 × 34 mm	50 mm
*/0500 V3.0	200 08 0141	44 × 64.5 × 36.5 mm	50 mm

SONOFLOW CO.55 type	Mounting holes	Mounting hole spacing
*/0250 V3.0	M4 × 8 mm	□ 36 mm
*/0375 V3.0	M4 × 8 mm	□ 36 mm
*/0500 V3.0	M4 × 8 mm	□ 36 mm

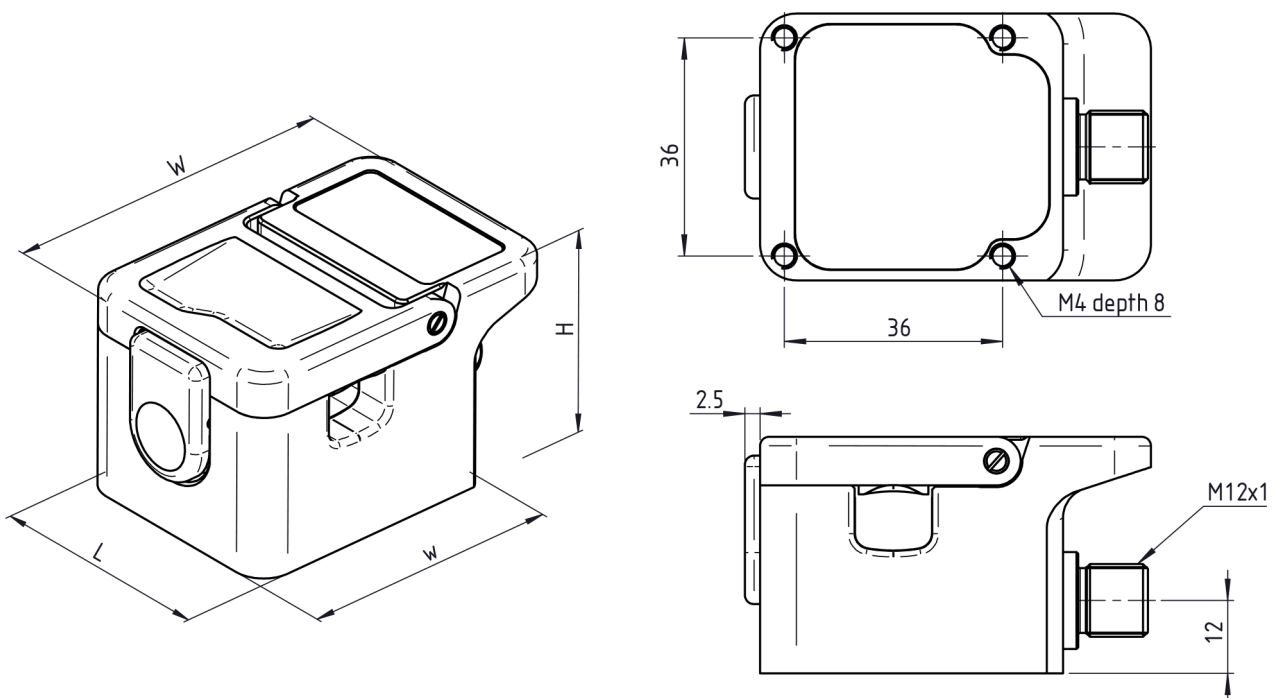

Sensor variant with cover clasp: medium design

SONOFLOW CO.55 type	Product No	Dimensions (L × W × H)	w (W without display)	h (H without display)
*/0625 V3.0	200 08 0138	66 × 84.5 × 43 mm	66 mm	41.5 mm
*/0750 V3.0	200 08 0142	66 × 84.5 × 45 mm	66 mm	43.5 mm

* W = Width without handle (see drawing))

SONOFLOW CO.55 type	Mounting holes	Mounting hole spacing
*/0625 V3.0	M6 × 8 mm	□ 55 mm
*/0750 V3.0	M6 × 8 mm	□ 55 mm

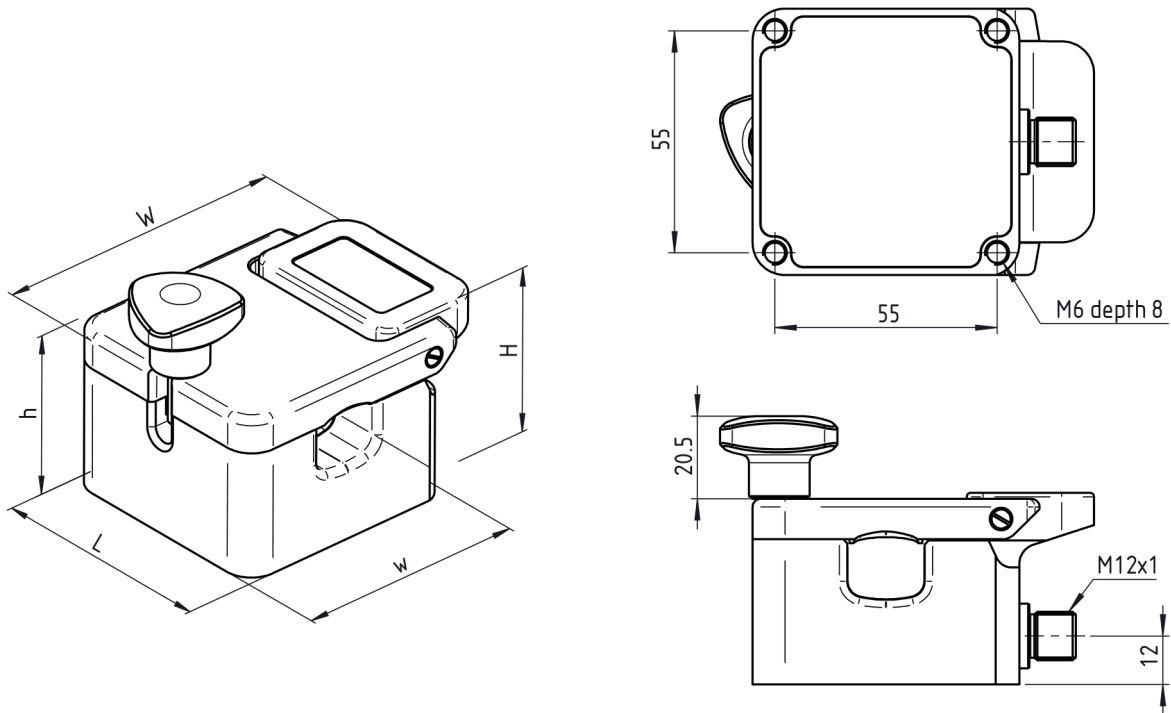

Sensor variant with handle (H)

For applications on tubes with large outer diameters, the corresponding sensors are equipped with a locking screw (handle) to assist handling when inserting the tube.

SONOFLOW CO.55 type	Product No	Dimensions (L × W × H) [Height with handle]	w (W without display)	h (H without display)
*/1375SDH V3.0	200 08 0143	66 × 84.5 × 61 [81.5] mm	75 mm	59.5

SONOFLOW CO.55 type	Mounting holes	Mounting hole spacing
*/1375SDH V3.0	M6 × 8 mm	□ 55 mm

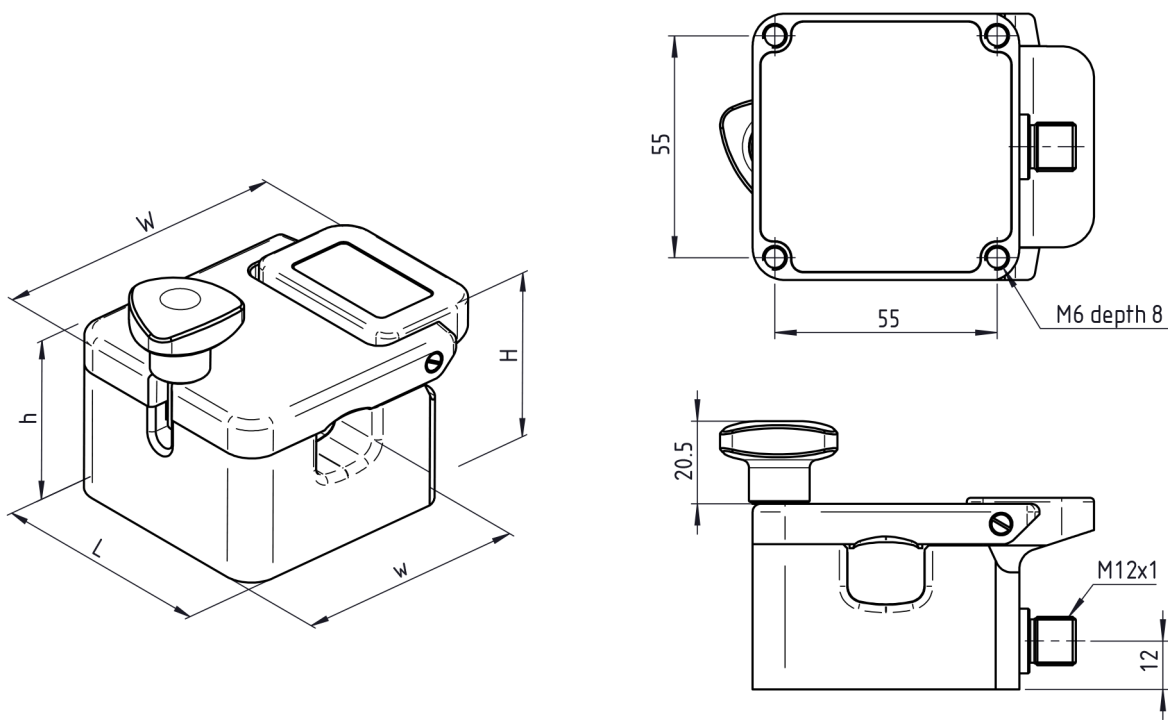

Drawings are not to scale. Dimensions in mm, unless otherwise specified. Information is subject to change without notice. SONOTEC is a registered trademark.



Manufacturer

SONOTEC GmbH
 Thüringer Str. 33
 06112 Halle (Saale)
 Germany

Tel.: +49 345 13317-0
sonotec@sonotec.de
www.sonotec.eu

Contact USA

SONOTEC US Inc.
 10 Newton Pl., Ste. 100
 Hauppauge, NY 11788
 USA

Tel.: +1 631 4154758
sales@sonotecusa.com
www.sonotecusa.com